

\* MD304 from 0.04 west of Front St (corp. limits) west to a point 0.08 east of Kidwell Ave is maintained by Centreville.

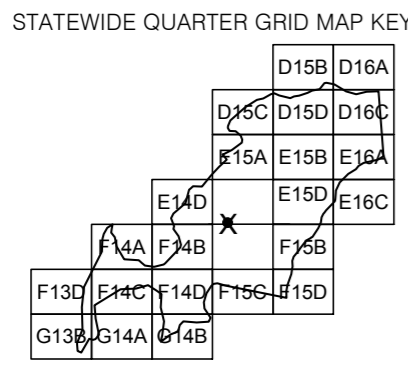
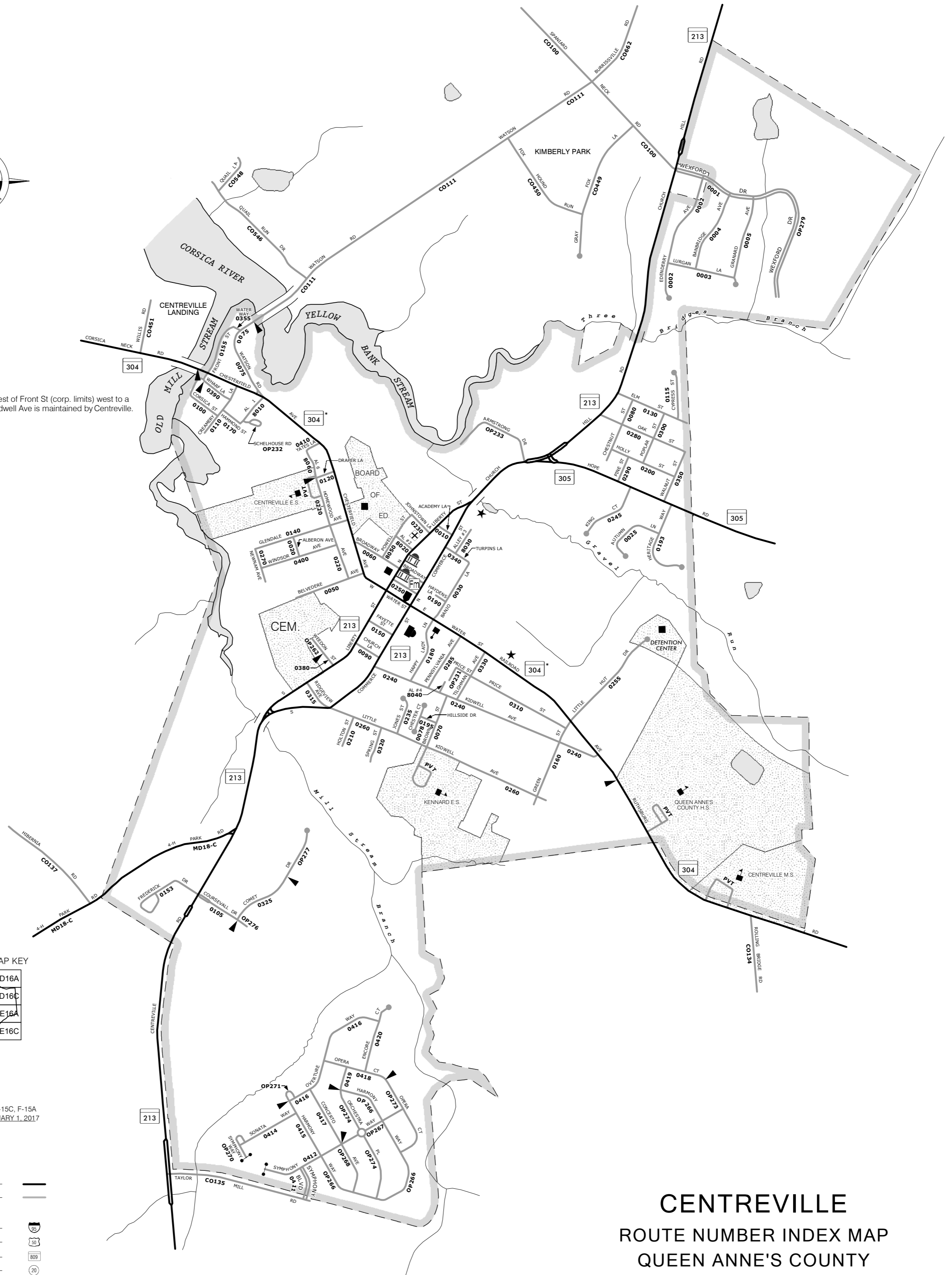

TOWN LOCATED ON GRID MAPS E-15C, F-15A  
MUNICIPAL INDEX MAP REVISED TO JANUARY 1, 2017

**LEGEND**

- ROAD CLASSIFICATION**
- State Highway
  - County/Local Road
- ROUTE MARKERS**
- Interstate Numbered Highway
  - U.S. Numbered Highway
  - State Numbered Highway
  - Interchange Exit
  - Municipal Route Number
  - County Route Number
  - Other Public Route Number
  - U.S. Government Route Number
  - Jurisdiction Marker

**ROADSIDE CULTURE**

- Army
- Boundary Monument
- Building/Structure
- Camping Facility
- College (Junior)
- College/University
- City/Town Hall
- Courthouse
- Md. Dept. of Agriculture Farmers Market
- Fire/Rescue
- Garage/SHA/County/Municipal
- Gate/Barricade
- Golf Course/Country Club
- Hospital
- Hospital w/ 24 hour Emergency Room
- Library
- Lighthouse
- Motor Vehicle Administration
- Park and Ride Location
- Police Station
- Post Office
- Radio/Microwave/TV Tower
- Salt Dome
- School
- Shopping Center/Mall
- VEIP Station
- Welcome Center
- Yacht Club/Marina

**INFORMATION SUMMARY**

BOUNDARY:  
ACTS OF GENERAL ASSEMBLY, 1983  
REVISED TO NOVEMBER 21, 2010  
HIGHWAYS REVISED TO JANUARY 1, 2017  
PHOTO REVISED: 2016  
CENSUS 4,285 (2010)

THIS MAP WAS CREATED USING MARYLAND STATE PLANE  
COORDINATE 5,000 FOOT GRID VALUES BASED ON  
THE 1983/1991 NORTH AMERICAN DATUM(NAD) HARN.

DISCLAIMER: THE DATA AND RELATED MATERIALS CONTAINED HEREIN ARE PROVIDED  
"AS IS" AND WERE CREATED TO MEET A SPECIFIC BUSINESS NEED OF THE  
MARYLAND STATE HIGHWAY ADMINISTRATION (SHA). ANY OTHER USE, WHILE NOT  
PROHIBITED, IS THE SOLE RESPONSIBILITY OF THE USER WHO SHALL ASSUME ALL  
LIABILITY REGARDING THE FITNESS OF USE OF THE INFORMATION.  
MUNICIPAL BOUNDARIES ARE BASED ON DATA OBTAINED FROM THE  
MARYLAND DEPARTMENT OF PLANNING (MDP).

**CENTREVILLE  
ROUTE NUMBER INDEX MAP  
QUEEN ANNE'S COUNTY  
MARYLAND**

PREPARED BY THE  
**MARYLAND DEPARTMENT OF TRANSPORTATION**  
STATE HIGHWAY ADMINISTRATION  
IN COOPERATION WITH THE  
**U.S. DEPARTMENT OF TRANSPORTATION**  
FEDERAL HIGHWAY ADMINISTRATION

**PUBLISHED: 2017**

