

STATEWIDE GRID MAP KEY

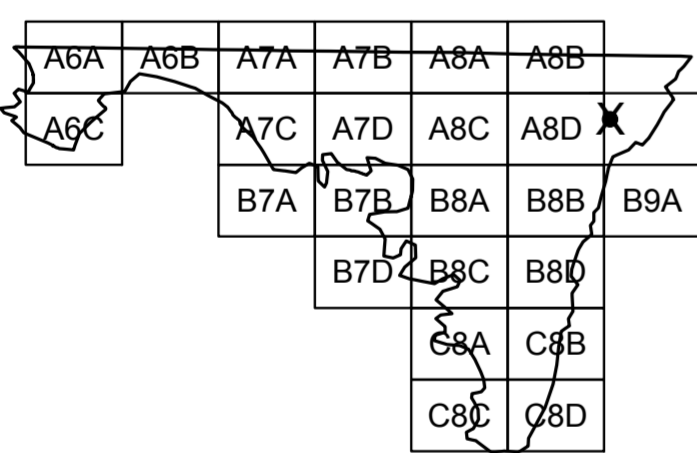

TOWN LOCATED ON GRID MAPS A8D, A9C
MUNICIPAL INDEX MAP REVISED TO JANUARY 1, 2017

LEGEND

- ROAD CLASSIFICATION**
- State Highway
- County/Local Road
- ROUTE MARKERS**
- Interstate Numbered Highway
- U.S. Numbered Highway
- State Numbered Highway
- Interchange Exit
- Municipal Route Number
- County Route Number
- Other Public Route Number
- U.S. Government Route Number
- Jurisdiction Marker
- ROADSIDE CULTURE**
- Armory
- Boundary Monument
- Building/Structure
- Camping Facility
- College (Junior)
- College/University
- City/Town Hall
- Courthouse
- Md. Dept. of Agriculture Farmers Market
- Fire/Rescue
- Garage/SHA/County/Municipal
- Gate/Barricade
- Golf Course/Country Club
- Hospital
- Hospital w/ 24 hour Emergency Room
- Library
- Lighthouse
- Motor Vehicle Administration
- Park and Ride Location
- Police Station
- Post Office
- Radio/Microwave/TV Tower
- Salt Dome
- School
- Shopping Center/Mall
- VEIP Station
- Welcome Center
- Yacht Club/Marina

NOTES:
 MD 66 - Water St from Railroad La to Pennsylvania Ave is maintained by Smithsburg
 MD 66 - Pennsylvania Ave from Water St to 0.10 mile North is maintained by Smithsburg

INFORMATION SUMMARY

BOUNDARY:
 ACTS OF GENERAL ASSEMBLY, 1983
 REVISED TO SEPTEMBER 19, 2008
 HIGHWAYS REVISED TO JANUARY 1, 2017
 PHOTO REVISED: 2016
 CENSUS 2.975 (2010)

THIS MAP WAS CREATED USING MARYLAND STATE PLANE
 COORDINATE 5,000 FOOT GRID VALUES BASED ON
 THE 1983/1991 NORTH AMERICAN DATUM(NAD) HARN.

DISCLAIMER: THE DATA AND RELATED MATERIALS CONTAINED HEREIN ARE PROVIDED
 AS IS AND WERE CREATED TO MEET A SPECIFIC BUSINESS NEED OF THE
 MARYLAND STATE HIGHWAY ADMINISTRATION (SHA). ANY OTHER USE, WHILE NOT
 PROHIBITED, IS THE SOLE RESPONSIBILITY OF THE USER WHO SHALL ASSUME ALL
 LIABILITY REGARDING THE FITNESS OF USE OF THE INFORMATION.
 MUNICIPAL BOUNDARIES ARE BASED ON DATA OBTAINED FROM THE
 MARYLAND DEPARTMENT OF PLANNING (MDP).

SMITHSBURG
 ROUTE NUMBER INDEX MAP
 WASHINGTON COUNTY
 MARYLAND

PREPARED BY THE
 MARYLAND DEPARTMENT OF TRANSPORTATION
 STATE HIGHWAY ADMINISTRATION

IN COOPERATION WITH THE
 U.S. DEPARTMENT OF TRANSPORTATION
 FEDERAL HIGHWAY ADMINISTRATION

PUBLISHED: 2017

