

WASHINGTON D.C.

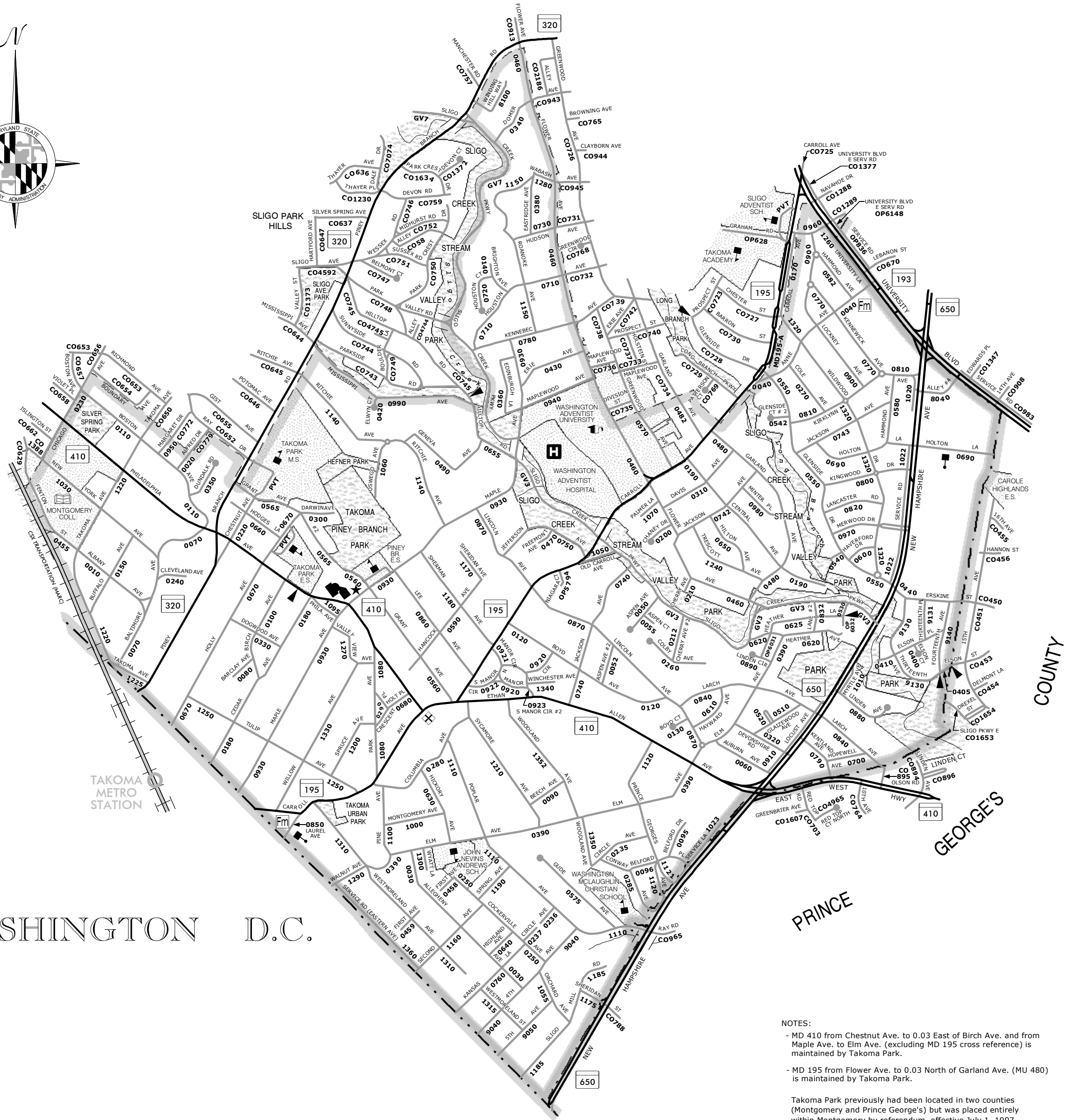

NOTES:  
 - MD 410 from Chestnut Ave. to 0.03 East of Birch Ave. and from Maple Ave. to Elm Ave. (excluding MD 195 cross reference) is maintained by Takoma Park.  
 - MD 195 from Flower Ave. to 0.03 North of Garland Ave. (MU 480) is maintained by Takoma Park.  
 Takoma Park previously had been located in two counties (Montgomery and Prince George's) but was placed entirely within Montgomery by referendum, effective July 1, 1997.

**LEGEND**

- ROAD CLASSIFICATION**
- State Highway
  - County/Local Road
- ROUTE MARKERS**
- Interstate Numbered Highway
  - U.S. Numbered Highway
  - State Numbered Highway
  - Interchange Exit
  - Municipal Route Number
  - County Route Number
  - Other Public Route Number
  - U.S. Government Route Number
  - Jurisdiction Marker
- ROADSIDE CULTURE**
- Army
  - Boundary Monument
  - Building/Structure
  - Camping Facility
  - College (Junior)
  - College/University
  - City/Town Hall
  - Courthouse
  - Md. Dept. of Agriculture Farmers Market
  - Fire/Rescue
  - Garage/SHA/County/Municipal
  - Gate/Barricade
  - Golf Course/Country Club
  - Hospital
  - Hospital w/ 24 hour Emergency Room
  - Library
  - Lighthouse
  - Motor Vehicle Administration
  - Park and Ride Location
  - Police Station
  - Post Office
  - Radio/Microwave/TV Tower
  - Salt Dome
  - School
  - Shopping Center/Mall
  - VEIP Station
  - Welcome Center
  - Yacht Club/Marina

**STATEWIDE QUARTER GRID MAP KEY**

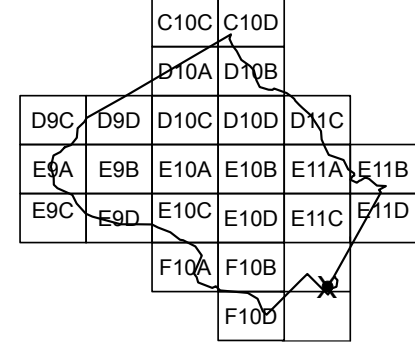

TOWN LOCATED ON GRID MAPS F11A, F11C  
 MUNICIPAL INDEX MAP REVISED TO JANUARY 1, 2017

**INFORMATION SUMMARY**

BOUNDARY:  
 ACTS OF GENERAL ASSEMBLY, 1983  
 REVISED TO MAY 12, 2011  
 HIGHWAYS REVISED TO JANUARY 1, 2017  
 PHOTO REVISED: 2014  
 CENSUS 16,715 (2010)

THIS MAP WAS CREATED USING MARYLAND STATE PLANE  
 COORDINATE 5,000 FOOT GRID VALUES BASED ON  
 THE 1983/1991 NORTH AMERICAN DATUM(NAD) HARN.

DISCLAIMER: THE DATA AND RELATED MATERIALS CONTAINED HEREIN ARE PROVIDED  
 'AS IS' AND WERE CREATED TO MEET A SPECIFIC BUSINESS NEED OF THE  
 MARYLAND STATE HIGHWAY ADMINISTRATION (SHA). ANY OTHER USE, WHILE NOT  
 PROHIBITED, IS THE SOLE RESPONSIBILITY OF THE USER WHO SHALL ASSUME ALL  
 LIABILITY REGARDING THE FITNESS OF USE OF THE INFORMATION.  
 MUNICIPAL BOUNDARIES ARE BASED ON DATA OBTAINED FROM THE  
 MARYLAND DEPARTMENT OF PLANNING (MDP).

**TAKOMA PARK  
 ROUTE NUMBER INDEX MAP  
 MONTGOMERY COUNTY  
 MARYLAND**

PREPARED BY THE  
**MARYLAND DEPARTMENT OF TRANSPORTATION**  
 STATE HIGHWAY ADMINISTRATION  
 IN COOPERATION WITH THE  
**U.S. DEPARTMENT OF TRANSPORTATION**  
 FEDERAL HIGHWAY ADMINISTRATION

PUBLISHED: 2017

