

WALKERSVILLE ROUTE NUMBER INDEX MAP FREDERICK COUNTY MARYLAND

PREPARED BY THE
MARYLAND DEPARTMENT OF TRANSPORTATION
STATE HIGHWAY ADMINISTRATION
IN COOPERATION WITH THE
U.S. DEPARTMENT OF TRANSPORTATION
FEDERAL HIGHWAY ADMINISTRATION

PUBLISHED: 2017

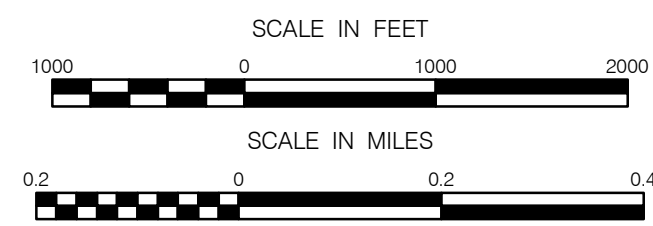

INFORMATION SUMMARY

BOUNDARY:
ACTS OF GENERAL ASSEMBLY, 1983
REVISED TO APRIL 28, 2012
HIGHWAYS REVISED TO JANUARY 1, 2017
PHOTO REVISED: 2014
CENSUS 5,800 (2010)

THIS MAP WAS CREATED USING MARYLAND STATE PLANE
COORDINATE 5,000 FOOT GRID VALUES BASED ON
THE 1983/1991 NORTH AMERICAN DATUM(NAD) HARN.

DISCLAIMER: THE DATA AND RELATED MATERIALS CONTAINED HEREIN ARE PROVIDED
AS IS AND WERE CREATED TO MEET A SPECIFIC BUSINESS NEED OF THE
MARYLAND STATE HIGHWAY ADMINISTRATION (SHA). ANY OTHER USE, WHILE NOT
PROHIBITED, IS THE SOLE RESPONSIBILITY OF THE USER WHO SHALL ASSUME ALL
LIABILITY REGARDING THE FITNESS OF USE OF THE INFORMATION.
MUNICIPAL BOUNDARIES ARE BASED ON DATA OBTAINED FROM THE
MARYLAND DEPARTMENT OF PLANNING (MDP).

LEGEND

- ROAD CLASSIFICATION**
- State Highway
 - County/Local Road
- ROUTE MARKERS**
- Interstate Numbered Highway
 - U.S. Numbered Highway
 - State Numbered Highway
 - Interchange Exit
 - Municipal Route Number
 - County Route Number
 - Other Public Route Number
 - U.S. Government Route Number
 - Jurisdiction Marker
- ROADSIDE CULTURE**
- Armory
 - Boundary Monument
 - Building/Structure
 - Camping Facility
 - College (Junior)
 - College/University
 - City/Town Hall
 - Courthouse
 - Md. Dept. of Agriculture Farmers Market
 - Fire/Rescue
 - Garage/SHA/County/Municipal
 - Gate/Barricade
 - Golf Course/Club
 - Hospital
 - Hospital w/ 24 hour Emergency Room
 - Library
 - Lighthouse
 - Motor Vehicle Administration
 - Park and Ride Location
 - Police Station
 - Post Office
 - Radio/Microwave/TV Tower
 - Salt Dome
 - School
 - Shopping Center/Mall
 - VEIP Station
 - Welcome Center
 - Yacht Club/Marina

STATEWIDE QUARTER GRID MAP KEY

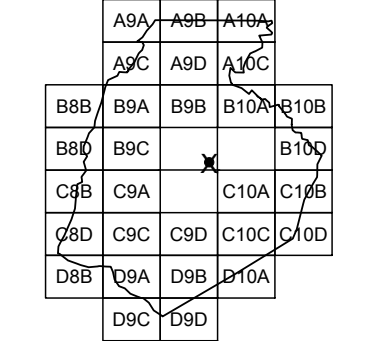

TOWN LOCATED ON GRID MAPS: B9D, B10C, C9B
MUNICIPAL INDEX MAP REVISED TO JANUARY 1, 2017